

## Discrete With Trench / Field Stop IGBT, Ultra Fast Recovery Diode.

### Features

- $V_{CE}=1200V$   $I_C=150A$
- Low  $V_{CE(sat)}$  with Positive Temperature Coefficient
- Trench+ Field Stop Technology

### Applications

- Motor Drives
- Servo Drives



### Equivalent Circuit Schematic

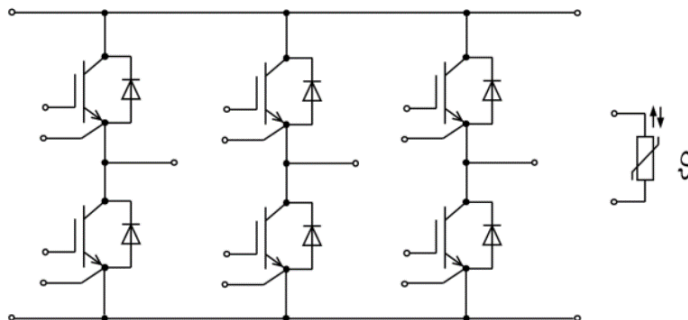

### IGBT - Inverter

#### Maximum Rated Values

Symbol	Description	Conditions	Values	Unit
$V_{CES}$	Collector-Emitter Voltage	$T_{vj}=25^{\circ}C$	1200	V
$V_{GES}$	Gate-Emitter Peak Voltage	$T_{vj}=25^{\circ}C$	$\pm 20$	V
$I_C$	Continuous DC Collector Current	$T_C=100^{\circ}C$	150	A
$I_{CRM}$	Repetitive Peak Collector Current	$t_p=1ms$	300	A
$P_{tot}$	Total Power Dissipation	$T_C=25^{\circ}C, T_{vj\ max}=175^{\circ}C$	789	W

**Characteristic Values**

Symbol	Description	Conditions	Values			Unit
			Min.	Typ.	Max.	
$V_{CE(sat)}$	Collector-Emitter Saturation Voltage	$V_{GE}=15V, I_C=150A, T_{vj}=25^{\circ}C$	---	1.80	---	V
		$V_{GE}=15V, I_C=150A, T_{vj}=125^{\circ}C$	---	1.98	---	V
$V_{GE(th)}$	Gate Threshold Voltage	$V_{GE}=V_{CE}, I_C=2.0mA$	5.0	5.8	7.0	V
$I_{CES}$	Collector-Emitter Cut-Off Current	$V_{CE}=1200V, V_{GE}=0V$	---	---	1.0	mA
$I_{GES}$	Gate-Emitter Leakage Current	$V_{GE}=\pm 20V, V_{CE}=0V$	---	---	$\pm 600$	nA
$R_{Gint}$	Internal gate resistor	$T_{vj}=25^{\circ}C$	---	5	---	$\Omega$
$C_{ies}$	Input Capacitance	$V_{CE}=25V, V_{GE}=0V, f=1MHz$	---	12.6	---	nF
$C_{res}$	Reverse Transfer Capacitance		---	0.5	---	nF
$t_{d(on)}$	Turn-on Delay Time	$V_{CC}=600V$ $V_{GE}=\pm 15V$ $I_C=150A$ $R_G=2.0\Omega$ Inductive Load $T_{vj}=25^{\circ}C$	---	173	---	ns
$t_r$	Turn-on Rise Time		---	42	---	ns
$t_{d(off)}$	Turn-off Delay Time		---	385	---	ns
$t_f$	Turn-off Fall Time		---	88	---	ns
$E_{on}$	Turn-on Switching Loss		---	8.2	---	mJ
$E_{off}$	Turn-off Switching Loss		---	12.4	---	mJ
$I_{SC}$	Short Circuit data	$V_{GE}=15V, V_{CC}=600V$ $t_p=10\mu s, T_{vj}=25^{\circ}C$	---	600	---	A
$R_{thJC}$	Thermal Resistance, Junction to Case	Per IGBT	---	---	0.19	K/W
$T_{VJOP}$	Virtual Junction Temperature	Under Switching	-40	---	150	$^{\circ}C$

**Diode - Inverter  
Maximum Rated Values**

Symbol	Description	Conditions	Values	Unit
$V_{RRM}$	Repetitive Peak Reverse Voltage	$T_{vj}=25^{\circ}C$	1200	V
$I_F$	Continuous DC Forward Current	$T_C=100^{\circ}C$	150	A
$I_{FRM}$	Repetitive Peak Collector Current	$t_p=1ms$	300	A

**Characteristic Values**

Symbol	Description	Conditions	Values			Unit
			Min.	Typ.	Max.	
V <sub>F</sub>	Forward Voltage	I <sub>F</sub> =150A, V <sub>GE</sub> =0V, T <sub>vj</sub> =25°C	---	1.90	---	V
		I <sub>F</sub> =150A, V <sub>GE</sub> =0V, T <sub>vj</sub> =125°C	---	1.97	---	V
I <sub>RM</sub>	Peak Reverse Recovery Current	I <sub>F</sub> =150A, V <sub>R</sub> =600V, V <sub>GE</sub> =-15V T <sub>vj</sub> =25°C	---	180	---	A
Q <sub>r</sub>	Recovered Charge		---	12	---	uC
E <sub>rec</sub>	Reverse Recovery Energy		---	5.1	---	mJ
T <sub>VJ OP</sub>	Virtual Junction Temperature	Under Switching	-40	---	150	°C

**NTC-Thermistor  
Characteristic Values**

Symbol	Description	Conditions	Values			Unit
			Min.	Typ.	Max.	
R <sub>25</sub>	Rated Resistance	T <sub>C</sub> =25°C	---	5	---	KΩ
B <sub>25/50</sub>	B Value	$R_2 = R_{25} \exp [B_{25/50}(1/T_2 - 1/(298 K))]$	---	3380	---	K

**Module**

Symbol	Description	Conditions	Values	Unit
V <sub>ISOL</sub>	Isolation Test Voltage	RMS, f=50Hz, t=1min	4	KV
	Material of module baseplate		Cu	
	Internal Isolation	Basic Insulation (Class 1, IEC 61140)	Al <sub>2</sub> O <sub>3</sub>	
	Creepage Distance	Terminal to Heatsink Terminal to Terminal	10	mm
	Clearance	Terminal to Heatsink Terminal to Terminal	7.5	mm

Symbol	Description	Conditions	Values			Unit
			Min.	Typ.	Max.	
L <sub>sCE</sub>	Stray Inductance Module		---	21	---	nH
R <sub>CC+EE'</sub>	Module lead resistance, terminals-chip		---	1.8	---	mΩ
T <sub>stg</sub>	Storage Temperature		-40	---	125	°C
M	Mounting torque for module mounting		3.00	---	6.00	Nm
G	Weight		---	300	---	g

# Typical Characteristics

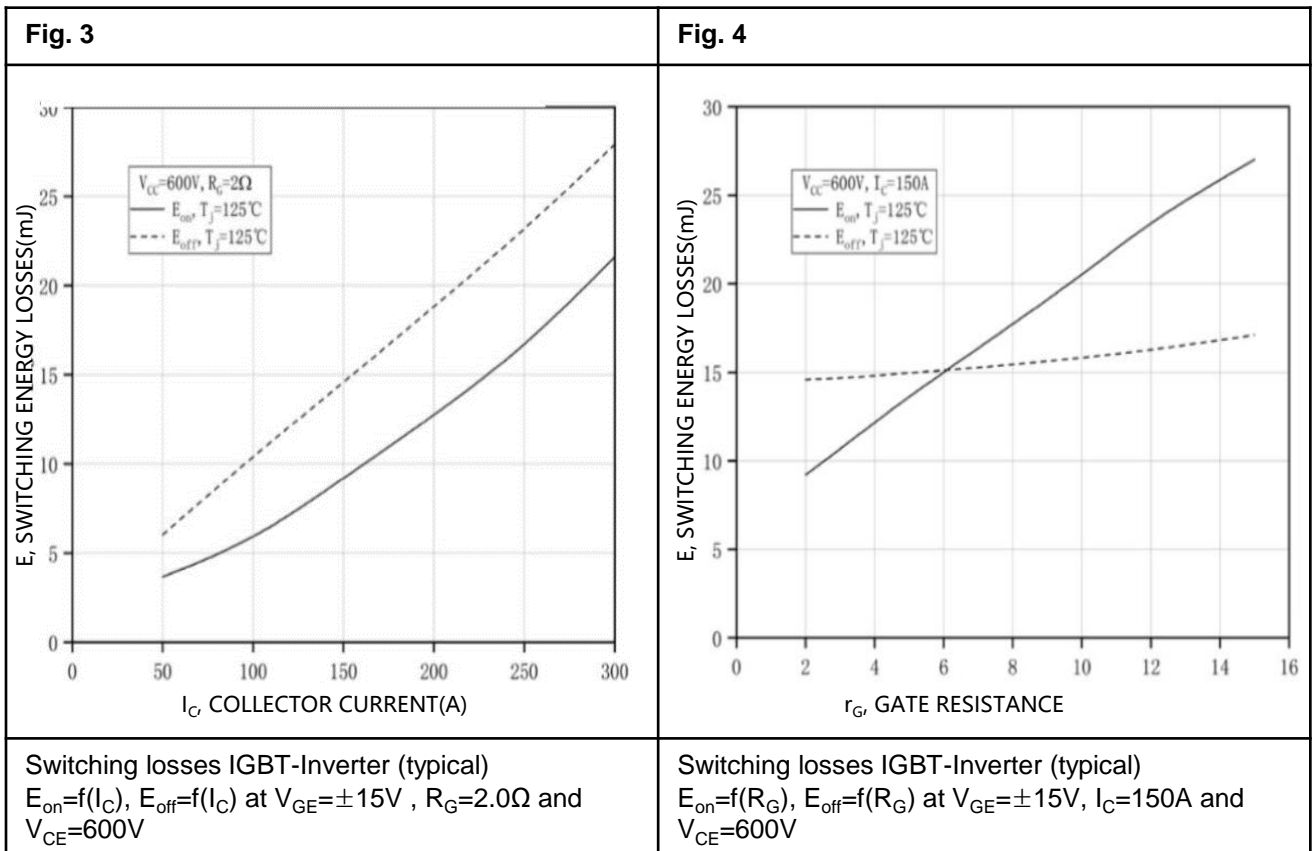
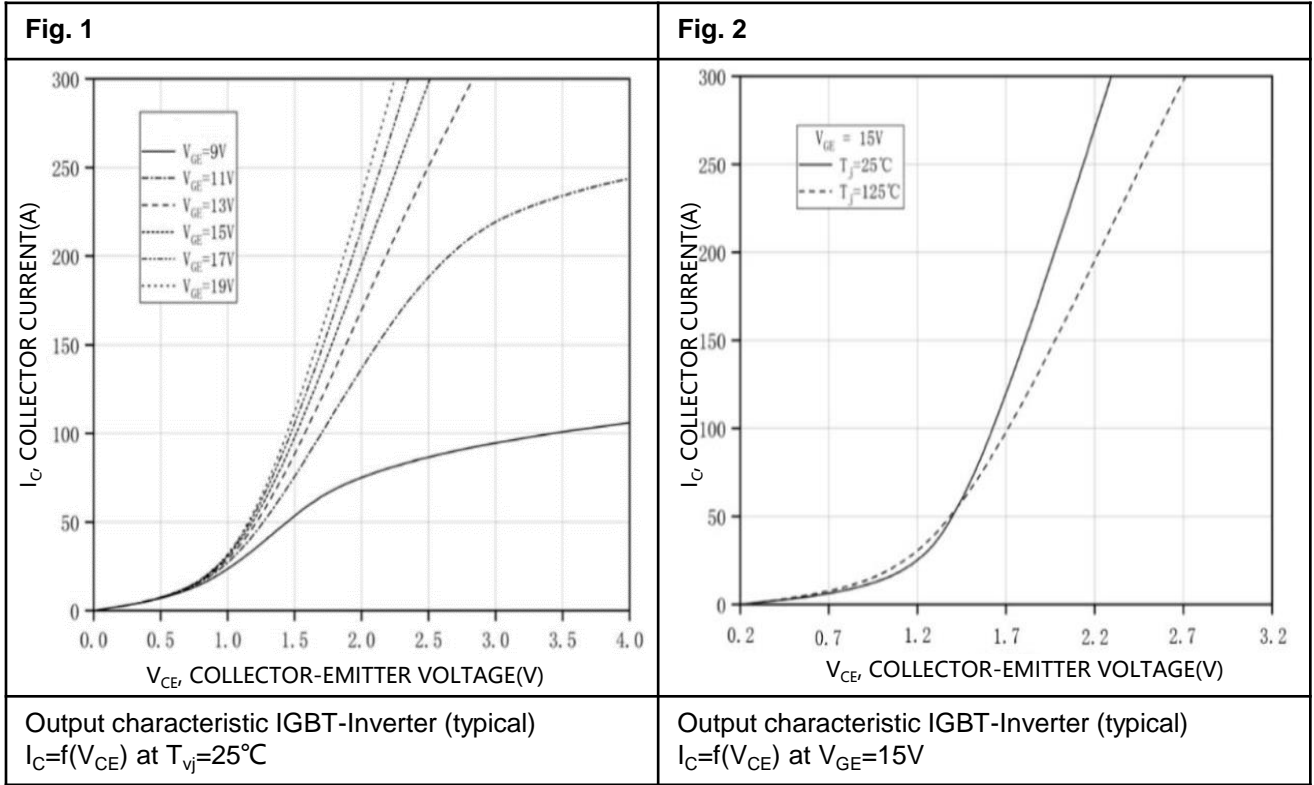

# Typical Characteristics

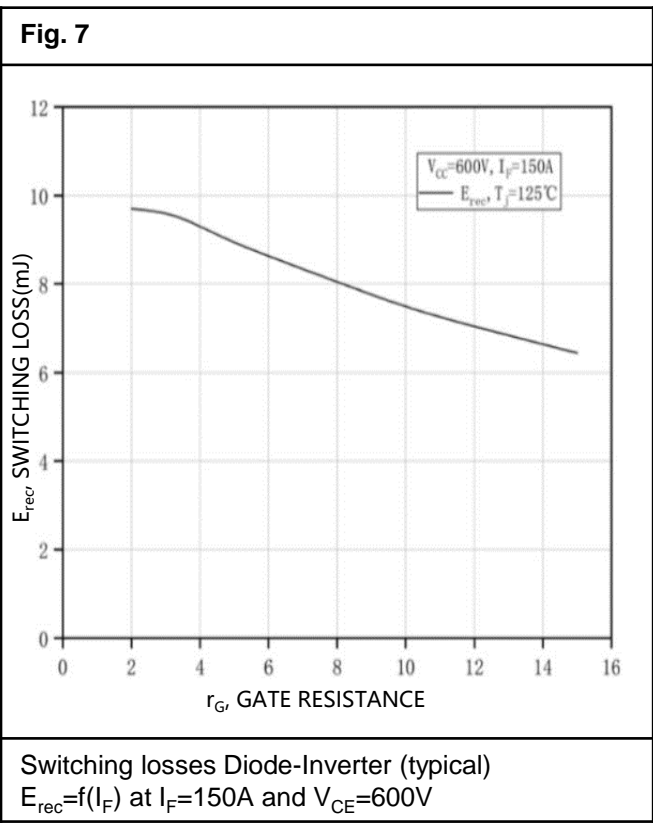
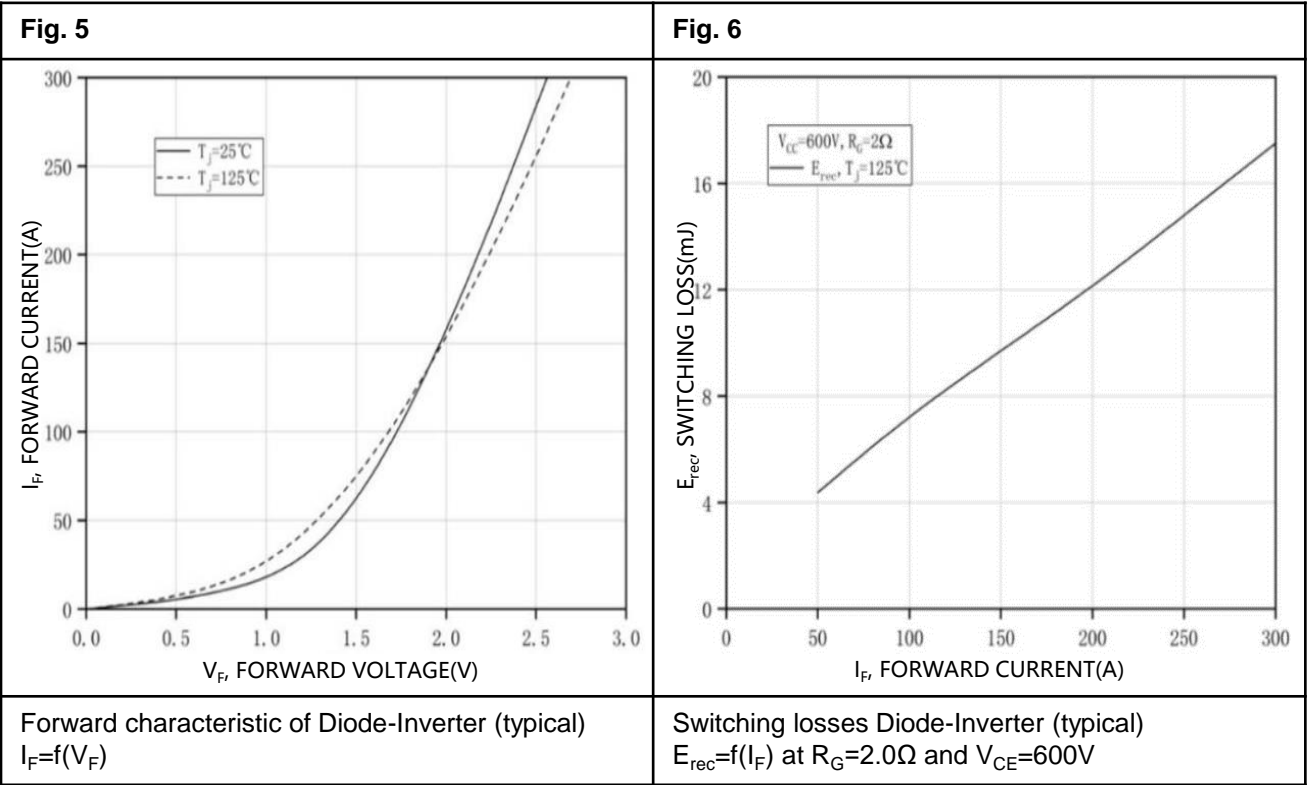

## Circuit Diagram

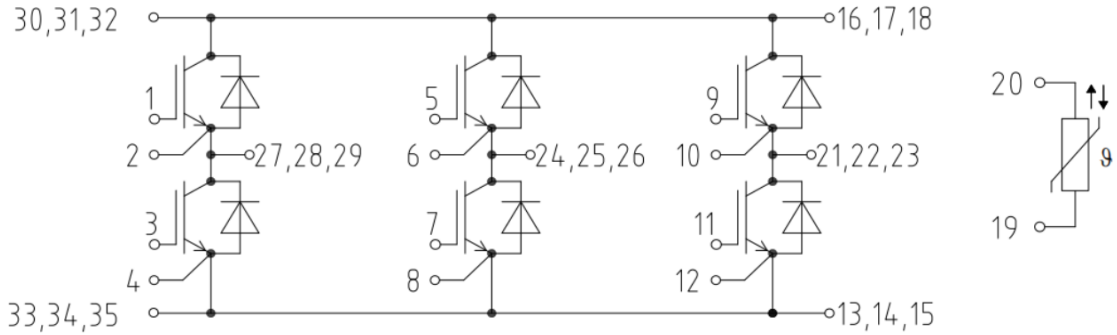

## Package Outlines (mm)

